

Arihant

स्पर्श

Newsletter

A Touch of Excellence, Every Month

M A R C H 2 0 2 5



Table of Contents

01

MESSAGE OF THE MONTH

02

SPOTLIGHT OF THE MONTH

- Featured Articles
- Arihant Electrical at the India-Qatar Business Forum 2025!
- Arihant Electrical at the India-Japan Business Conference 2025

03

PEOPLE & CULTURE

- February Birthday Celebrations
- March Birthdays

04

MOMENTS OF LAUGHTER & FUN

Message of the month

Dear Team Arihant,

As we welcome the festival of colors, I extend my warmest wishes to you and your loved ones for a very Happy Holi! This vibrant festival reminds us of the beauty of togetherness, the joy of new beginnings, and the power of unity—values that are deeply embedded in the culture of Arihant Electrical.

Just as Holi blends different colors into a beautiful masterpiece, our workplace thrives on the diversity of our talented team. Each of you brings unique strengths, perspectives, and ideas, making Arihant Electrical a place where innovation flourishes and success is a collective achievement. Let this festival inspire us to celebrate our differences, embrace teamwork, and continue working together with harmony and mutual respect.

Holi is also a time of renewal—an opportunity to let go of past challenges and welcome fresh energy and enthusiasm. Let's take this moment to refresh our spirits, strengthen our bonds, and step forward with positivity and determination.

As you celebrate with colors, laughter, and sweets, I encourage you to spread joy, kindness, and goodwill within the Arihant family and beyond. May this festival fill your hearts with happiness and your lives with vibrant moments to cherish.

Have a safe and joyful Holi! We would love to see how you are celebrating—feel free to share your colorful moments with the team.

With warm regards,
HR Desk
Arihant Electrical

Spotlight of the Month

Featured Articles

Dive into this month's insightful articles, covering industry trends, innovations, and expert perspectives. Stay informed, stay inspired, and explore ideas that drive excellence at Arihant Electricals

1

Why Your Engagement on Company's Social Media is important

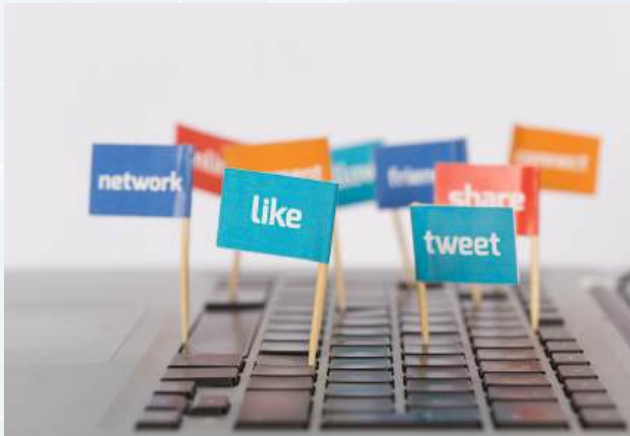

In today's digital era, social media is a powerful tool for businesses to connect with their audience. However, simply posting content isn't enough. Engagement—likes, comments, shares, and interactions—is the key to unlocking the true potential of social media marketing.

Why Engagement Matters

Social media platforms use engagement metrics to determine the visibility of a post. The more interactions a post receives, the higher its chances of appearing in more feeds, reaching a larger audience, and creating a lasting impact.

Benefits of Engagement for Business Growth

- **Increased Visibility**

When users like, comment, or share a post, it signals to the algorithm that the content is valuable. This boosts the post's reach and helps businesses gain more exposure without spending extra on advertisements.

- **Builds Trust and Credibility**

A business with an active and engaged audience appears more credible. Comments and shares act as social proof, showing potential customers that the brand is trusted and valued.

- **Encourages Community Building**

When followers engage with content, they become part of a community. Responding to comments and encouraging discussions foster a deeper connection between the brand and its audience, leading to long-term customer loyalty.

- **Boosts Sales and Conversions**

Engaged followers are more likely to become paying customers. When people see positive interactions on a brand's page, they feel more confident in making a purchase or trying a service.

- **Cost-Effective Marketing**

Organic engagement reduces the need for excessive paid advertising. When users share content, it acts as free promotion, expanding reach and attracting new potential customers.

How You Can Support Business

- **Like and React:** A simple like helps improve content visibility.
- **Comment:** Share your thoughts, ask questions, or tag a friend.
- **Share:** If you find a post valuable, share it with your network.
- **Save and Revisit:** Saving posts tells the platform that the content is useful.

Your engagement is more powerful than you think! Supporting brands by actively interacting with their content can help them grow and continue to provide valuable products and services, & this is what exactly is to be done by each of us.. Let's build a thriving digital community together!

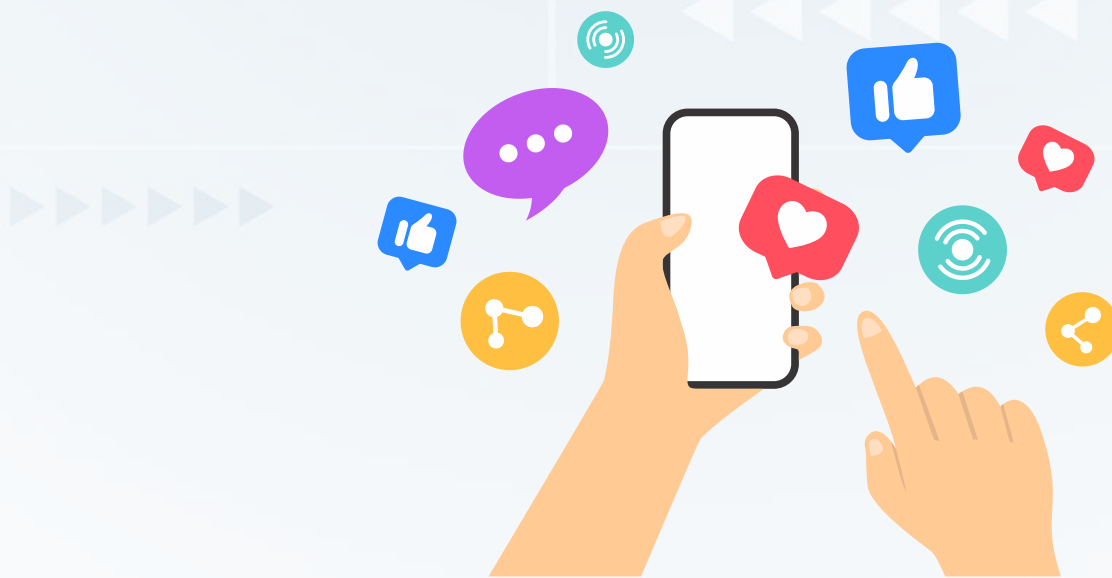

2 आप सफलतम मैनेजर किसे मानते हैं?

आगे बढ़ने से पहले अपने मन में इस प्रश्न का उत्तर सोच ले। शायद ही आप सही उत्तर तक पहुंच पाए -

सही उत्तर है

"एक आम गृहिणी।" जी हां -

एक गृहिणी परिवार से किसी का ट्रांसफर नहीं कर सकती।

किसी को सस्पेंड नहीं कर सकती।

किसी को टर्मिनेट नहीं कर सकती।

और,

किसी को अपॉइंट भी नहीं कर सकती।

परन्तु फिर भी सबसे काम करवाने की क्षमता रखती है।

किससे, क्या और कैसे कराना है...

कब प्रेम के राग में हौले से काम पिरोना है...

और कब राग सप्तक पर उच्च स्वर में भैरवी सुना कर जरूरी कामों को अंजाम तक पहुंचाना है...

उसे पता होता है।

मानव संसाधन प्रबंधन का इससे बेहतर क्या उदाहरण हो सकता है?

बड़े बड़े उद्योगों में भी कभी कभी इसलिए काम रुक जाता है क्योंकि जरूरी फ्यूल नहीं था या कोई स्पेयर पार्ट उपलब्ध नहीं था या कोई रॉ मटेरियल कम पड़ गया। पर किसी गरीब से गरीब घर में भी नमक कम नहीं पड़ता।

शायद बहुत याद करने पर भी आप को वह दिन याद न आ पाए जिस दिन मां आपको खाने में सिर्फ इसलिए कुछ नहीं दे पाई कि बनाने को कुछ नहीं था या गैस खत्म हो गई थी या कुकर का रिंग खराब हो गया था।



हर कमोबेशी और हर समस्या का विकल्प एक गृहिणी रखती है। वो भी बिल्कुल खामोशी से।

सामग्री प्रबंधन एवं संचालन, संधारण प्रबंधन का इससे बेहतर उदाहरण क्या हो सकता है ?

अचानक बड़ा खर्च आ जाने पर या किसी की बीमारी पर, बाकी सब बगलें झांकने लगते हैं। लेकिन वो फटाफट पुराने संदूको में छुपा कर रखे बचत के पैसे निकालती है, कुछ गहने गिरवी रखती है, कुछ घरों से सिर्फ साख के आधार पर उधार लेती है।

पर पैसे का इंतजाम कर ही लाती है।

संकटकालीन अर्थ प्रबंध का इससे बेहतर क्या उदाहरण हो सकता है?

निचले इलाकों में बेमौसम बारिश में घर में पानी भरने लगे या बिना खबर अचानक चार मेहमान आ जाएं।

सब के लिए आपदा प्रबंधन की योजना रहती है उसके पास।

और...

सारे प्रबंधन के लिए पास में है बस कुछ आंसू और कुछ मुस्कान।

लेकिन...

जो सबसे बड़ी चीज होती है...

वो है...

जिजीविषा, समर्पण और प्रेम।

सफल गृहिणी का सबसे बड़ा संबल होता है सब्र।

वही सब्र...

जिसके बारे में किसी ने बहुत सटीक कहा है...

सब्र का घूंट दूसरों को पिलाना कितना आसान लगता है।

खुद पियो तो, कतरा कतरा ज़हर लगता है।

संकलन, संपादन -

प्रमोद जैन



Healthy professional relationships refer to the positive, respectful, and supportive connections between individuals in a workplace or professional setting. These relationships are characterized by mutual trust, open communication, collaboration, and respect for each other's differences. They contribute to a productive and harmonious work environment where people feel valued, supported, and motivated.

Nurturing healthy professional relationships can really enhance your work life and career growth. Here are some key tips to consider:



1. Clear Communication

Open, honest, and respectful communication helps avoid misunderstandings and builds trust. It involves listening actively, giving constructive feedback, and expressing thoughts or concerns clearly.

2. Mutual Respect

Respect for each other's perspectives, ideas, and boundaries is crucial. This includes appreciating diversity and valuing the contributions of everyone on the team.

3. Trust

Trust is the foundation of any healthy relationship. Colleagues should feel confident that they can rely on each other to meet deadlines, fulfil responsibilities, and maintain confidentiality when necessary.

4. Support and Empathy

Offering support when a colleague faces challenges—whether personal or professional—creates a strong bond. Empathy allows for a deeper understanding of others' situations and fosters a compassionate environment.

5. Boundaries

Respecting personal boundaries—whether related to time, space, or personal matters—is important. Healthy professional relationships thrive when there's an understanding of what is acceptable and what isn't.

6. Collaboration and Teamwork

A successful team environment encourages collaboration, sharing ideas, and working toward common goals. Being open to others' ideas and willing to compromise contributes to a productive, positive workplace.

7. Appreciation and Recognition

Recognizing the efforts and achievements of colleagues builds morale and a sense of belonging. Acknowledging each other's hard work, even in small ways, can strengthen professional relationships.

8. Better Conflict Resolution

In any workplace, conflict is inevitable. Healthy professional relationships allow for open discussions and resolution of disagreements in a constructive and respectful manner. This helps to prevent conflicts from escalating and damaging the work environment.

9. Professionalism

Maintaining a level of professionalism helps establish trust and respect. This involves following workplace norms, being punctual, and ensuring that your behaviour is aligned with company values and ethics.

10. Personal Growth and Development

Supporting each other's professional development helps build relationships that are mutually beneficial. When colleagues encourage each other's growth and success, it can foster a sense of camaraderie and commitment.

By cultivating these qualities, you can create an environment where positive relationships can thrive, ultimately contributing to a healthier workplace culture and better career outcomes for everyone involved.

Benefit of Healthy Professional Relationship

Healthy professional relationships offer numerous benefits that can enhance both individual well-being and organizational success. Here are some key advantages:

1. Increased Job Satisfaction

Positive relationships at work contribute to a sense of belonging and support, making individuals feel more engaged and fulfilled in their roles. This can lead to higher overall job satisfaction and a better work-life balance.

2. Improved Collaboration and Teamwork

Healthy professional relationships foster a collaborative environment where individuals work together effectively. This improves problem-solving, creativity, and efficiency, leading to better results for the team and the organization.

3. Enhanced Communication

Trust and respect in professional relationships open the door for clear, honest, and constructive communication. This reduces misunderstandings and helps people express their needs and ideas more freely.

4. Increased Productivity and Efficiency

When colleagues work well together and communicate effectively, tasks can be completed more quickly and efficiently. People are more likely to go the extra mile for those they have positive relationships with, leading to higher productivity.

5. Boosted Morale and Motivation

Positive relationships can increase motivation by providing emotional support, encouragement, and a sense of camaraderie. When people feel valued and appreciated, they are more likely to stay motivated and perform well.

6. Increased Retention and Reduced Turnover

A workplace that fosters healthy relationships has a lower turnover rate. Employees are more likely to stay in an environment where they feel supported, respected, and connected with their colleagues.

7. Greater Career Growth Opportunities

Healthy relationships can lead to mentorship and networking opportunities, allowing individuals to advance in their careers. Colleagues who have a strong bond are more likely to recommend each other for promotions, projects, or professional development opportunities.

8. Better Mental and Emotional Well-being

Supportive work relationships contribute to mental and emotional well-being by providing a safe and empathetic environment. Positive interactions at work reduce stress and help people cope with challenges more effectively.

9. Positive Work Culture

When healthy relationships are cultivated across the organization, it helps create a positive, respectful, and inclusive work culture. A healthy culture attracts and retains top talent, promotes innovation, and improves overall employee well-being.

10. Improved Customer/Client Relationships

When internal teams work well together, it can also improve external interactions. A cohesive, well-functioning team is better equipped to meet customer needs and maintain strong client relationships.

11. Strengthened Leadership and Team Development

Healthy professional relationships are critical for effective leadership. Leaders who nurture positive relationships with their teams are better at motivating, guiding, and developing their employees, ultimately contributing to a stronger organization.

In sum, the benefits of healthy professional relationships extend beyond individual interactions—they contribute to overall workplace harmony, success, and well-being. Cultivating these relationships leads to a more productive, positive, and resilient work environment.



Nowadays fast charging through DC is getting more popular. To get faster charge-time it is necessary to have the external power conversion and it is important that this is galvanically isolated. Power electronics should be effective in terms of cost and should be considerably efficient. SiC Schottky diodes can be selectively used for the optimization of power electronics. Battery is charged with the help of the isolated DC output whereas the power conversion is not bound and has the ability of being active or passive with the estimated and normal wattage ranges from 50-300kW in the presence of 200-600 DC. Power conversion can be both unidirectional and bidirectional. The size of the transformer is proportional to the switching frequency. This article mainly focuses on the unidirectional power flow in the DC-DC section.

Isolated DC-DC converter topology

This is a unidirectional converter that is isolated in nature. Its primary winding is driven with the help of an H-bridge inverter that is single phase. The DC output is generated with the help of the full bridge rectifier and an output filter is required for the cleanliness of the DC output, which can either be CL or LC. A DC-DC converter with LC and CL filters is shown in figure 1. Snubbers are not required in case of CL filters for the rectification of the diodes. The waveform of the current in the H-bridge is triangular because of the discontinuous rectifier current. Higher current peaks are responsible for making triangular waveforms inefficient. There is a 120A current charge at 400 DC out and 500 DC in, as shown in figure. Using an LC output filter results in a continuous current which produces square waves with low current peaks in the H-bridge. Another advantage related to the use of LC filters is the high efficiency.

H-Bridge losses

The switching losses are most prominent when turning off the switching devices [1]. 50% of the IGBT losses at higher value occurs in comparison to the triangular waveform at the same level of DC output current and this all happens because of the higher peak of the current in a triangular waveform. For instance, the losses have been calculated on the basis of the 1200V on the IGBT technology that is switching at 10kHz. If the snubber rectifier is not designed properly then the partial offset can be detected in the IGBT losses.

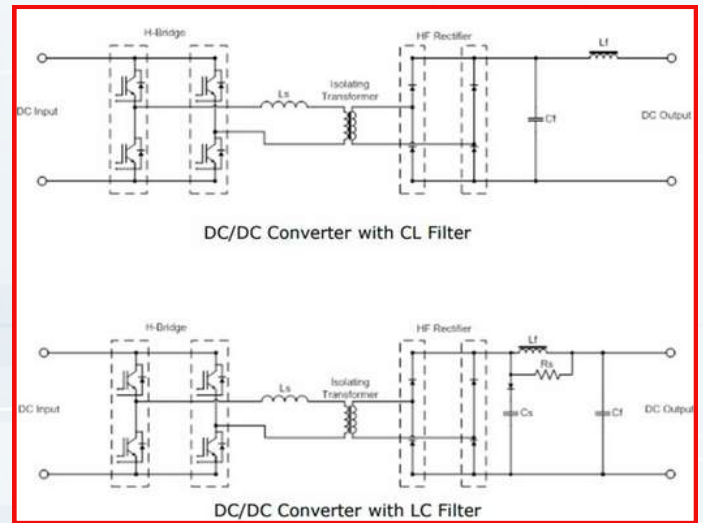
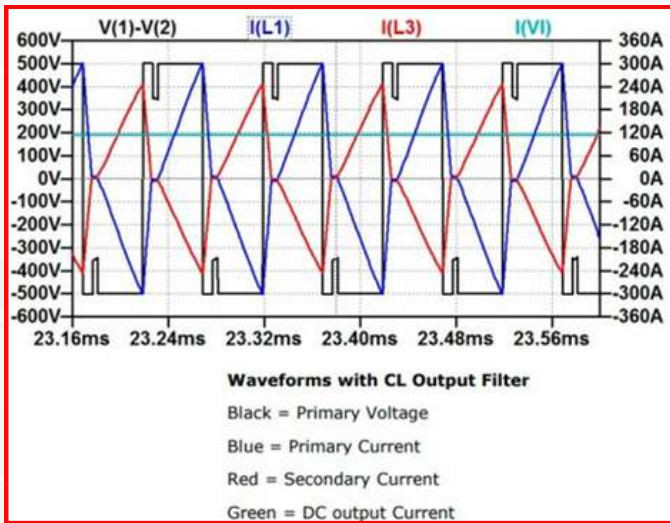

Design of rectifier snubber circuit

With a huge number of losses dissipating the rectifier snubber starts to become problematic [1]. It is important that the Q_{rr} in the diodes is absorbed by the snubber circuit and should be dissipated in the resistor and, because of this whole process, the efficiency gets reduced, and the need of large components is increased [1]. At this point there's no other help but a SiC diode.

Advantages of SiC Schottky diode

Some of the significant advantages that are associated with the SiC devices are:

- A tendency of lowering the loss of switching.
- Reverse recovery charge is not present.
- Small amount of charge at the capacitance of the junction, but it is not greater than the Q_{rr} at the normal Si PN junction.
- Easy and ready availability at the standard package of the industry.

Theoretical comparison of the two similarly sized rectifier modules

Here is a comparison of the same size Si and SiC modules. The voltage is set at 600V and the value of the snubber capacitor has been selected to be the optimal value to minimize the overshoot of the voltage.

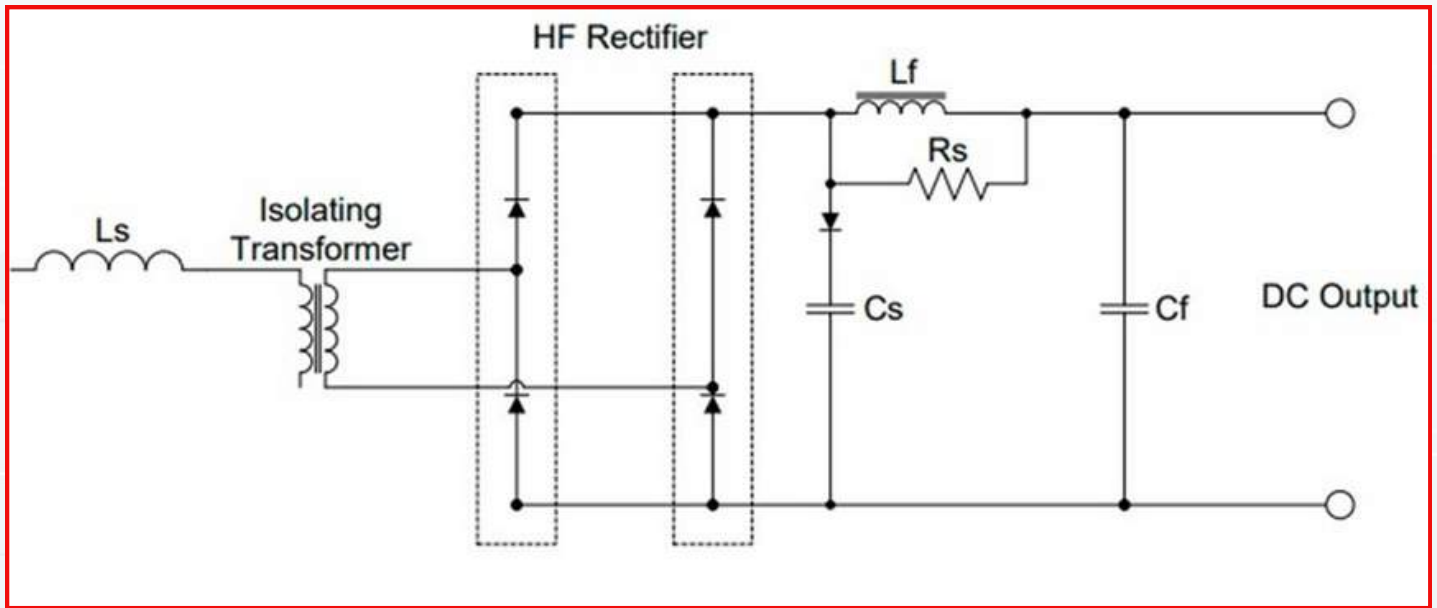

Conclusion

This article has given a handy and brief yet informative knowledge about the SiC Schottky diodes, their advantage, a comparison between Si and SiC diodes along with a detailed case study for an in-depth understanding of the concept.

SiC Schottky Diodes have the ability of increasing efficiency, reducing the size and reducing the cost of the DC-DC converters that are isolated in nature. A proper use of Schottky diodes have the potency of reducing the losses of the snubber in the rectifier circuit, thus resulting in a reduction in the switching losses. Furthermore, a great amount of reduction has been observed in the cost and the size of the components of the snubber. SiC devices are actually expensive so it is recommended to limit the usage of these devices and altern with some other best available option so that a significant advantage can be gained from it. All the data has been collected from the authentic source.

SUDHAKAR SHARMA
Marketing Department

Arihant Electrical at the India-Qatar Business Forum 2025!

We are proud to have been part of the India-Qatar Business Forum 2025, held at Hotel ITC Maurya, New Delhi. Organized by CII, Invest Qatar, and Qatar Chamber, the event brought together key industry leaders and policymakers to enhance trade relations between India and Qatar.

At Arihant Electrical, we believe in fostering strong international partnerships and exploring new growth opportunities. This forum provided valuable insights into emerging sectors, investment possibilities, and innovations shaping the future of global trade.

• Key Highlights from the Forum

- ✔ Discussions on key sectors like logistics, AI, and infrastructure development
- ✔ Exchange of MoUs to strengthen business collaborations
- ✔ Insights from prominent leaders, including:



- Shri Piyush Goyal, Hon'ble Minister of Commerce & Industry, Government of India.
- H.E. Sheikh Faisal bin Thani bin Faisal Al Thani, Hon'ble Minister of Commerce & Industry, State of Qatar
- Vijay Shekhar Sharma, Founder & CEO of Paytm, on digital transformation
- Shri Jitin Prasada, Hon'ble Minister of State for Commerce & Industry, on trade expansion strategies

Our participation in this prestigious event reinforces Arihant Electrical's commitment to expanding into global markets, driving innovation, and building strategic partnerships that contribute to India's economic growth.

We look forward to leveraging these insights and connections to create new opportunities for collaboration and business expansion.



Arihant Electrical at the India-Japan Business Conference 2025

Arihant Electrical was privileged to be part of the India-Japan Business Conference 2025, a significant platform that brought together industry leaders, policymakers, and innovators from both nations. The discussions focused on collaborations in infrastructure, manufacturing, and technological advancements, reinforcing the strong economic ties between India and Japan.

Strategic insights from distinguished leaders:

- **H.E. Mr. Keiichi Ono**, Ambassador of Japan to India - Opening remarks on Indo-Japan trade relations
- **Shri Jitin Prasada**, Hon'ble Minister of State, Ministry of Commerce & Industry - Discussing business policies and trade expansion
- **Shri Piyush Goyal**, Hon'ble Minister of Commerce & Industry (Online) - Sharing India's vision for global trade partnerships
- **Mr. Yoshihide Suga**, Chairman, Japan-India Association - Special message on strengthening bilateral cooperation
- **Mr. Yoshiyuki Enomoto**, Chairman, Japanese Chamber of Commerce and Industry in India & Chairperson, Mitsui & Co. India Pvt Ltd
- **Dr. Ranjeet Mehta**, CEO & Secretary General, PHD Chamber of Commerce & Industry
- **Dr. Kotaro Kataoka**, IIT Hyderabad Professor - Insights on India-Japan collaboration in science and technology



Strengthening India's Industrial Growth Through Indo-Japan Collaboration

- ◆ **Enhancing trade relations** to drive industrial and economic expansion
- ◆ **Attracting foreign investments** in infrastructure, defense, and manufacturing
- ◆ **Adopting advanced technologies** to improve operational efficiency
- ◆ **Expanding the 'Make in India' initiative** with Japanese expertise



Arihant Electrical remains committed to driving excellence, fostering global partnerships, and contributing to India's economic growth. Platforms like these open doors for valuable collaborations and new opportunities for business expansion.



People & Culture

At Arihant Electricals, our people are our greatest strength. This month, we celebrated birthdays, welcomed new team members, and fostered a positive workplace culture. Through these moments, we continue to build a collaborative and engaging work environment where everyone thrives!

February Birthday Celebration

Celebrating our incredible team member and wishing him joy, success, and prosperity!



Mr. Virender Sharma (Tool Room)

Upcoming Birthday in March

Wishing you joy, success, and a fantastic year ahead!

Name	DOB
Rajesh Sharma (Electrician)	5 March
Tanisha Verma	8 March
Satendra Singh	10 March
Yogesh Kumar Pandey, Kamal Kant	15 March
Arun Sharma	18 March
Manish Kumar Sharma (R&D)	19 March
Ankur Agarwal	29 March



Moments of Laughter & Fun



The Lazy Engineer & the Overworked Machine

A factory worker noticed that one particular machine was always overheating.

Worker: "Should we service it?"

Engineer: "Nah, let's just increase the fan speed."

A week later, the machine caught fire, causing a full production shutdown!

Factory Owner: "Why didn't we fix it earlier?!"

Engineer: "Well... the fan was still working!"

Moral: Temporary fixes can lead to permanent disasters!



Contact Us

E-mail

info@arihantelectricals.com

Phone

+91 – 120 – 6256192

Social Media

 [arihantelectr](#)

 [arihantelectr](#)

 [arihantelectricals](#)

Website

www.arihantelectricals.com

www.arisysel.com

HQ Address

Plot No. 60, Ecotech 12, Greater Noida,
Gautam Budh Nagar – 201 318, UP, India



We solicit your valuable suggestions and feedback to enhance this newsletter for future editions.